

<b>DTC</b>	<b>P2759</b>	<b>Torque Converter Clutch Pressure Control Solenoid Control Circuit Electrical (Shift Solenoid Valve SLU)</b>
------------	--------------	--

**DESCRIPTION**

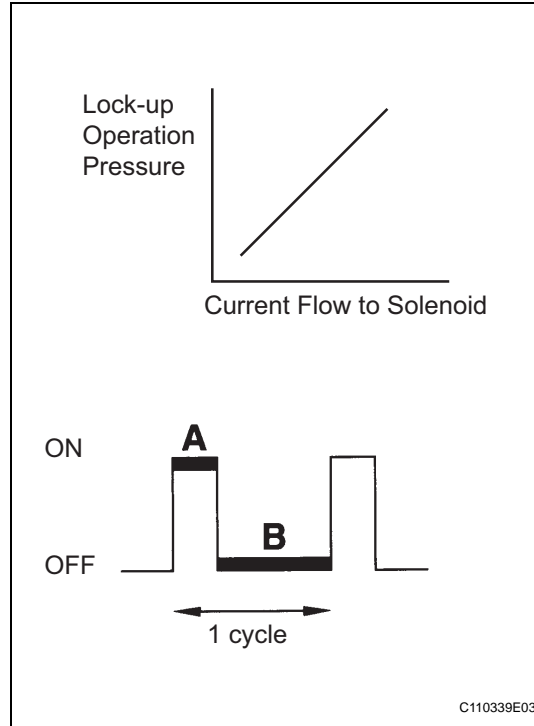

The current flow to the solenoid is controlled by the duty ratio\* of the ECM output signal. The higher the duty ratio becomes, the higher the lock-up hydraulic pressure becomes during the lock-up operation.

\*: The duty ratio is the ratio of the continuity to non-continuity in one cycle.

For example, if A is the period of continuity in one cycle, and B is the period of non-continuity, then Duty Ratio =  $A/(A+B) \times 100(\%)$ .

**AT**

DTC No.	DTC Detection Conditions	Trouble Areas
P2759	Open or short is detected in shift solenoid valve SLU circuit for 1 second or more while driving (1-trip detection logic)	<ul style="list-style-type: none"> <li>Open or short in shift solenoid valve SLU circuit</li> <li>Shift solenoid valve SLU</li> <li>ECM</li> </ul>

**MONITOR DESCRIPTION**

When an open or short is detected in the shift solenoid valve (SLU) circuit, the ECM determines that there is a malfunction. The ECM turns on the MIL and stores this DTC.

**MONITOR STRATEGY**

Related DTCs	P2759: Shift solenoid valve SLU/Range check
Required sensors/Components	Shift solenoid valve SLU
Frequency of operation	Continuous
Duration	Condition (A) and (B): 1 second
MIL operation	Immediate
Sequence of operation	None

### TYPICAL ENABLING CONDITIONS

The following conditions are common to Condition (A) and (B).

The monitor will run whenever the following DTCs are not present.	None
Ignition switch	ON
Starter	OFF

#### Condition (A)

Solenoid current cut status	Not cut
Battery voltage	11 V or more

#### Condition (B)

Battery voltage	8 V or more
-----------------	-------------

### TYPICAL MALFUNCTION THRESHOLDS

Either of the following conditions is met: Condition (A) or (B)

#### Condition (A)

Solenoid status (SLU) from Hybrid IC	Fail
--------------------------------------	------

#### Condition (B)

Hybrid IC status	Fail
------------------	------

### COMPONENT OPERATING RANGE

Shift solenoid valve SLU	Resistance: 5.0 to 5.6 Ω at 20°C (68°F)
--------------------------	---

### WIRING DIAGRAM

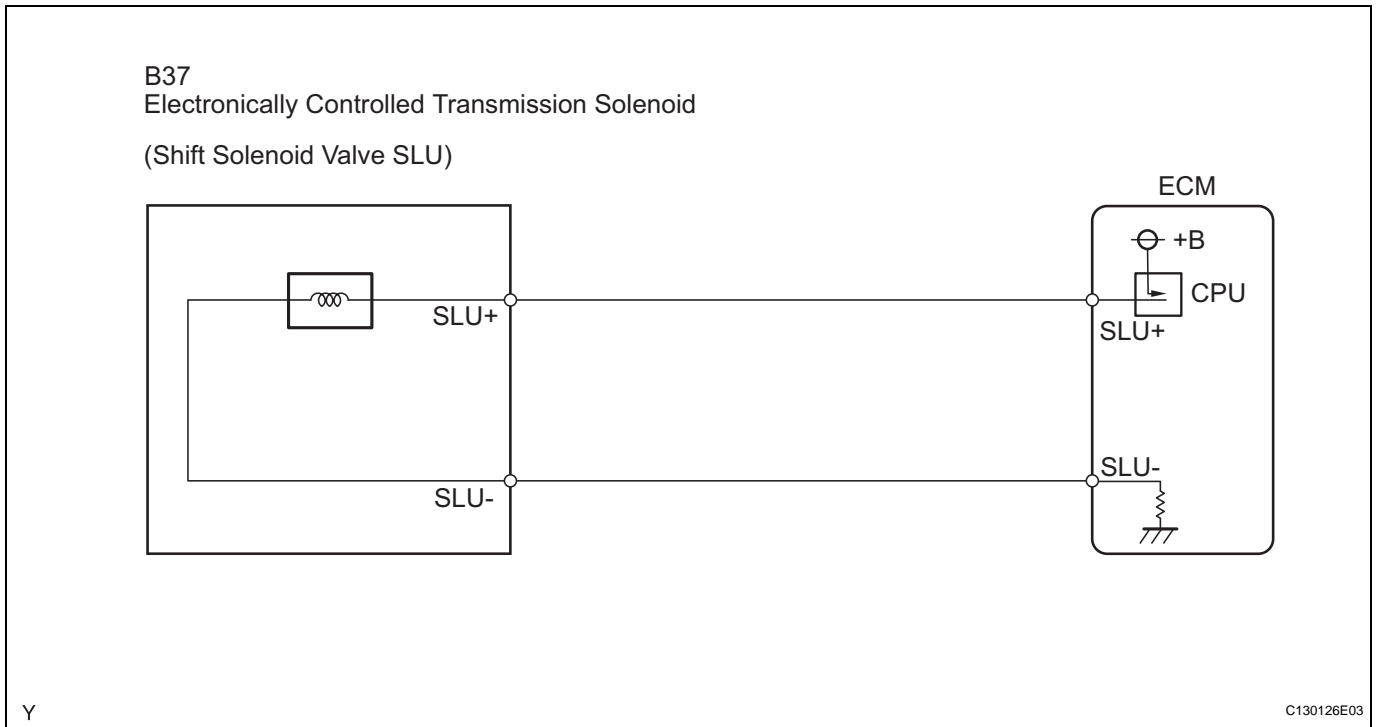

AT

**INSPECTION PROCEDURE**

**1 INSPECT TRANSMISSION WIRE (SLU)**

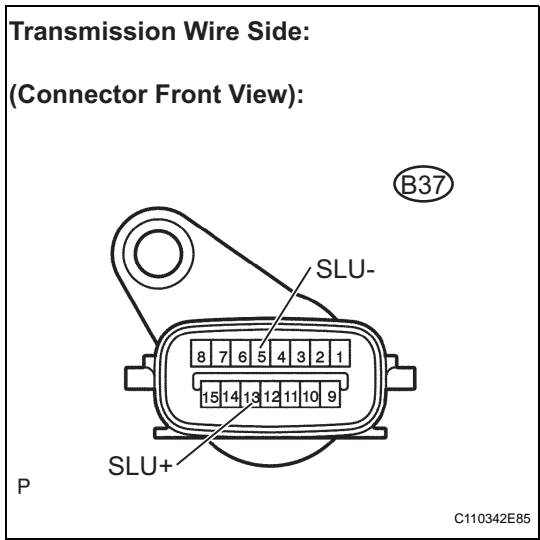

(a) Disconnect the transmission wire connector from the transmission.

(b) Measure the resistance.  
**Standard resistance**

Tester Connection	Specified Condition
13 (SLU+) - 5 (SLU-)	5.0 to 5.6 Ω at 20°C (68°F)

(c) Measure the resistance.  
**Standard resistance (Check for short)**

Tester Connection	Specified Condition
13 (SLU+) - Body ground	10 kΩ or higher
5 (SLU-) - Body ground	10 kΩ or higher

**NG** → **Go to step 3**

**OK**

**2 CHECK HARNESS AND CONNECTOR (TRANSMISSION WIRE - ECM)**

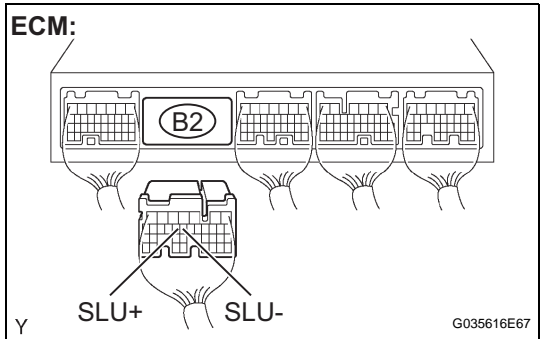

(a) Connect the transmission wire connector to the transmission.

(b) Disconnect the ECM connector.

(c) Measure the resistance.  
**Standard resistance**

Tester Connection	Specified Condition
B2-15 (SLU+) - B2-14 (SLU-)	5.0 to 5.6 Ω at 20°C (68°F)

(d) Measure the resistance.  
**Standard resistance (Check for short)**

Tester Connection	Specified Condition
B2-15 (SLU+) - Body ground	10 kΩ or higher
B2-14 (SLU-) - Body ground	10 kΩ or higher

**NG** → **REPAIR OR REPLACE HARNESS OR CONNECTOR**

**OK**

**REPLACE ECM**

**AT**

**3 INSPECT SHIFT SOLENOID VALVE SLU**

Shift Solenoid Valve SLU:

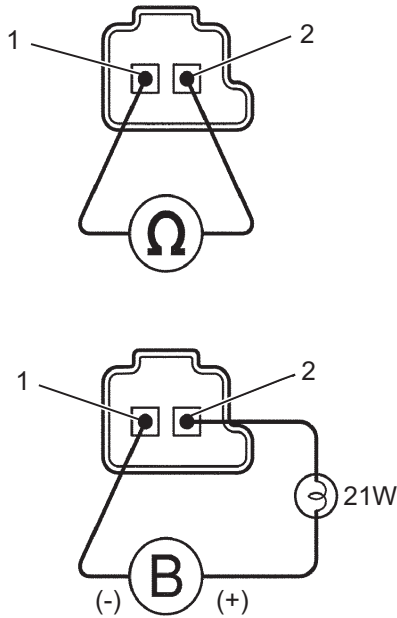

P

G020767E41

- (a) Remove the shift solenoid valve SLU.
- (b) Measure the resistance.

**Standard resistance**

Tester Connection	Specified Condition
1 - 2	5.0 to 5.6 Ω at 20°C (68°F)

- (c) Connect the positive (+) lead with a 21 W bulb to terminal 2 and the negative (-) lead to terminal 1 of the solenoid valve connector, then check the movement of the valve.

**OK:**

The solenoid makes operating sounds.

**NG** → **REPLACE SHIFT SOLENOID VALVE SLU**

**OK**

**REPAIR OR REPLACE TRANSMISSION WIRE**