

INSTALLATION

HINT:

The procedure described below is for the LH side. Use the same procedure for both the RH and LH sides, unless otherwise specified.

1. INSTALL NO. 2 BLACK OUT TAPE

(a) Application precautions.

(1) Application temperature.

1. If the temperature is below 15°C (59°F), using an infrared light, heat the base (body attachment surface) and black out tape up to between 20 and 30°C (68 and 86°F). If the temperature is over 35°C (95°F), perform the operation after lowering the temperature to below 35°C (95°F).

HINT:

- The most suitable temperature for applying the black out tape is 25°C (77°F).
- The black out tape cannot be applied correctly at low temperatures due to its stiffness and weak adhesion. The tape loses its consistency at high temperature.

(2) Pre-application procedure.

1. Any uneven twisting or dust on the base (body attachment surface) causes a defective appearance due to air being trapped under the black out tape during application. Make sure there is no uneven twisting or dust on or around the base or black out tape.

HINT:

When the air is dry in winter, put cardboard between the pieces of black out tape and keep it in a dry flat place.

(3) Handling.

1. Keep the black out tape in a dry flat level place because it is easily deformed.

NOTICE:

Do not fold, bend or expose the tape to high temperatures.

(4) Application method (Method of squeegee operation and application for general portions).

NOTICE:

- **The positioning accuracy must be within 1 mm (0.039 in.) when starting the application, otherwise, poor appearance and adhesion will result.**
- **Do not reuse black out tape that has been removed. It causes deformation and weak adhesion.**

1. In order to suppress bubble formation, slightly raise the portion not being pressed by the squeegee away from the base. Tilt the squeegee between 40 and 50° (in the pushing direction) and between 30 and 45° (in the pulling direction), and apply 20 to 30 N (2 to 3 kg, 4 to 6 lb) of pressure at a velocity of 3 to 7 cm/sec. while pushing out the air.

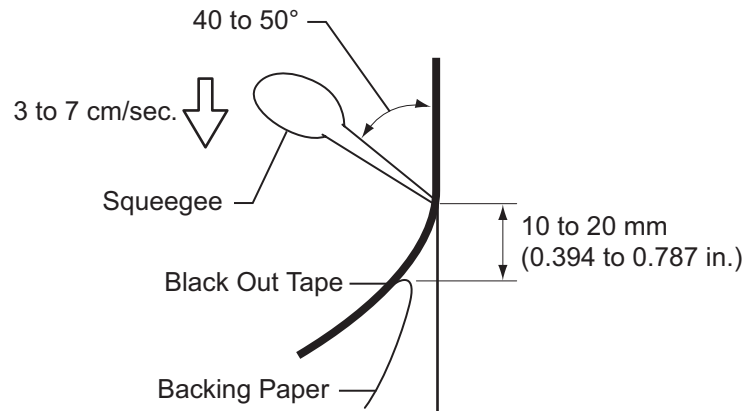
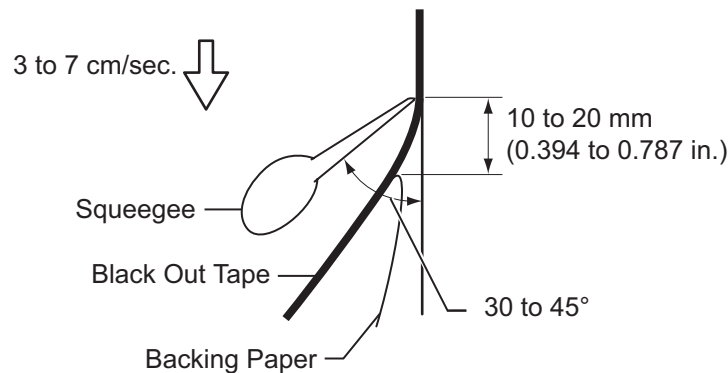
Pushing Direction:**Pulling Direction:**

T

B114637E01

NOTICE:

While using the squeegee, do not change the speed, stop the operation or change the force of the application. Doing so could cause a streak across the surface of the black out tape called a shock line. While using the squeegee, keep the speed and force of application constant and the angle correct.

ET

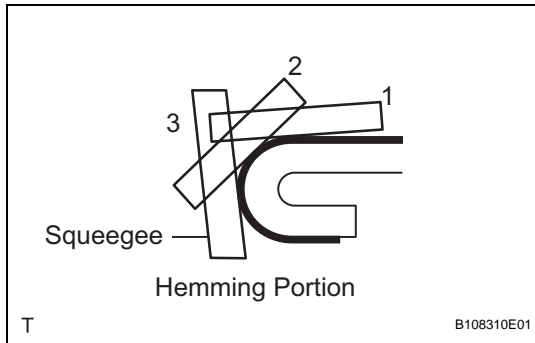
**HINT:**

- The squeegee can be tilted in either the pushing direction or in the pulling direction against the attachment portion.
- Perform the procedure while peeling the backing paper off the black out tape, 10 to 20 mm (0.394 to 0.787 in.) from the end of the squeegee.

(5) Application method (Method of squeegee operation).

1. If the tape cannot be pressed in one step using the squeegee, perform the application in several steps. Using your finger or a thicker part of the squeegee, gradually apply the tape to the small R portion of the hemming portion in 2 or 3 steps.

HINT:

Peel off the backing paper at the hemming portion and apply the black out tape with your finger or a thicker part of the squeegee.

(6) Application method (Method of squeegee operation and application method for corner sections).

1. Carefully apply the tape using a finger after peeling the backing paper off the corner section.
2. In order to prevent appearance deterioration caused by the tape pin angle, turn in the tape at the corner after heating the black out tape with a dryer.

(7) Inspection.

1. Repeat the application using new black out tape.

NOTICE:

Do not use a needle to rectify bubbles in any glazed tape being applied to the outer panel, in order to make scratches virtually imperceptible.

HINT:

Use an instant adhesive if the hemming or corner portions of the black out tape are partially peeled off.

(b) Clean the attachment surface (Using an infrared light).

- (1) Using an infrared light, heat any black out tape and adhesive remaining on the body.

CAUTION:

Do not burn yourself with the heated body or infrared light.

- (2) Using a shop rag or piece of cloth, rub the remaining black out tape and adhesive off the body.
- (3) Using a non-residue solvent, clean the attachment surface.

- (c) Clean the attachment surface (Using a tape removal disc).
- (1) Set the 8 discs in the holder and insert the removal disc into an air drill or electric drill.
NOTICE:
Use an electric drill of which the no-load operation is 2,000 to 3,000 r/min.
 - (2) Using a tape removal disc, rub the remaining black out tape and adhesive off the body.
NOTICE:
 - **Wear protective glasses during the operation.**
 - **Rotate and operate the disc in the correct direction.**
 - **Visually check that the cutting portion is not damaged while rubbing the remaining black out tape and adhesive off the body.**
 - (3) Using a non-residue solvent, clean the attachment surface.
- (d) Apply new No. 2 black out tape to the positions shown in the illustration.

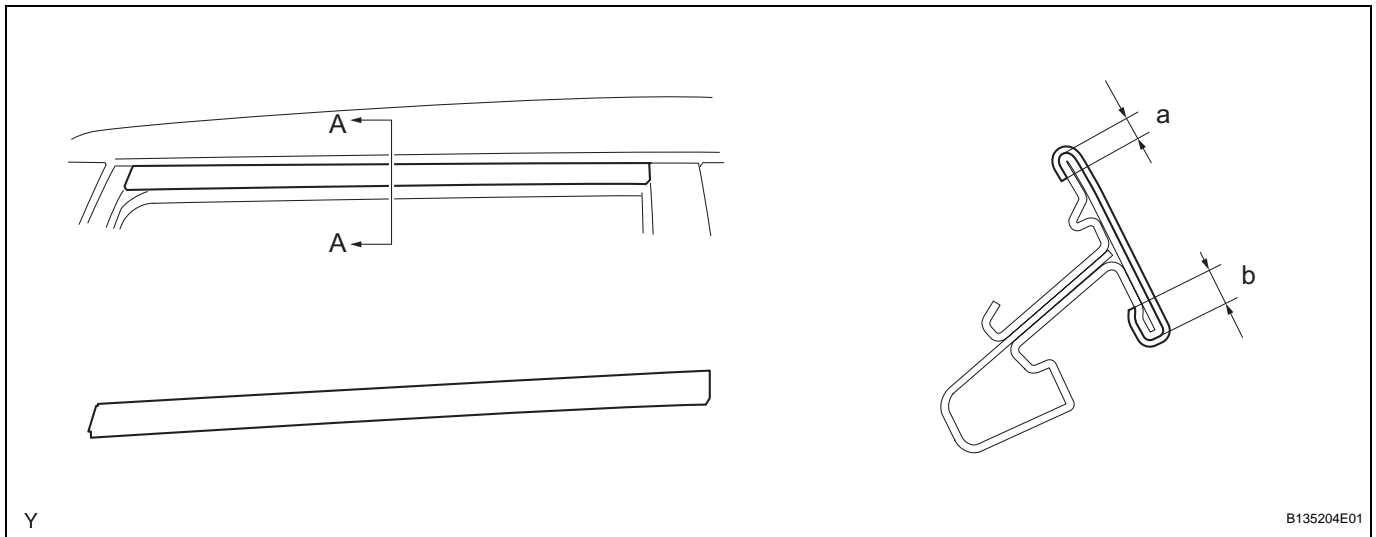

Installation position

Mark	Measurement
a	2 to 4 mm (0.079 to 0.157 in.)
b	4 to 6 mm (0.157 to 0.236 in.)

2. INSTALL NO. 3 BLACK OUT TAPE

- (a) Application precautions.
HINT:
Use the same procedure as for the No. 2 black out tape.
- (b) Clean the attachment surface (Using an infrared light).
HINT:
Use the same procedure as for the No. 2 black out tape.

- (c) Clean the attachment surface (Using a tape removal disc).
HINT:
Use the same procedure as for the No. 2 black out tape.
- (d) Apply new No. 3 black out tape to the positions shown in the illustration.

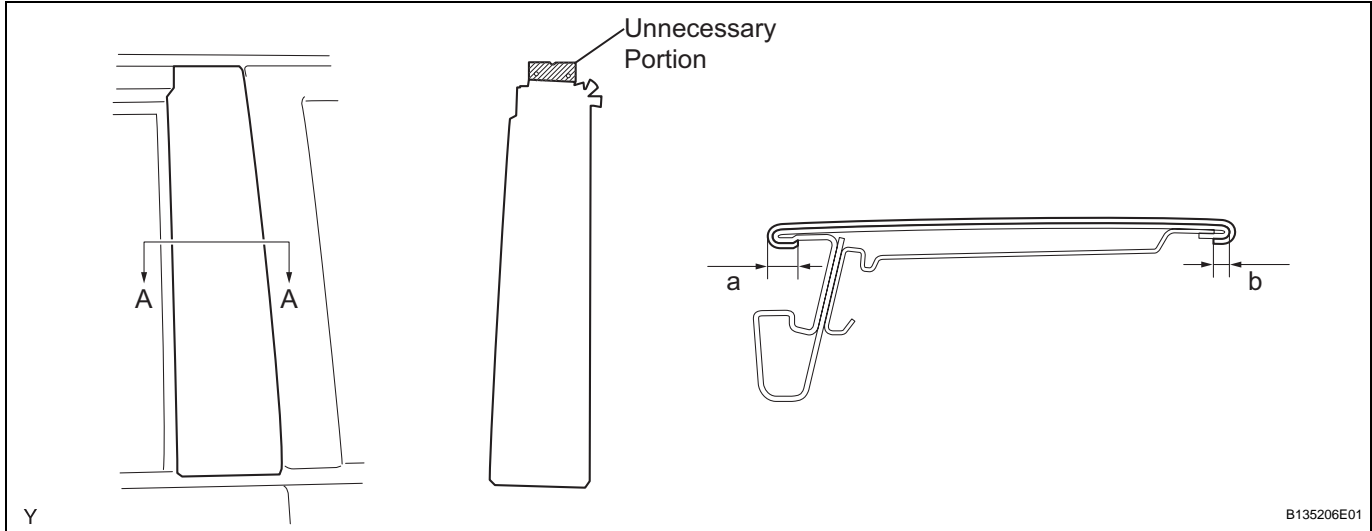

Installation position

Mark	Measurement
a	4 to 6 mm (0.157 to 0.236 in.)
b	2 to 4 mm (0.079 to 0.157 in.)

3. INSTALL NO. 1 BLACK OUT TAPE

- (a) Application precautions.
HINT:
Use the same procedure as for the No. 2 black out tape.
- (b) Clean the attachment surface (Using an infrared light).
HINT:
Use the same procedure as for the No. 2 black out tape.
- (c) Clean the attachment surface (Using a tape removal disc).
HINT:
Use the same procedure as for the No. 2 black out tape.

- (d) Apply new No. 1 black out tape to the positions shown in the illustration.

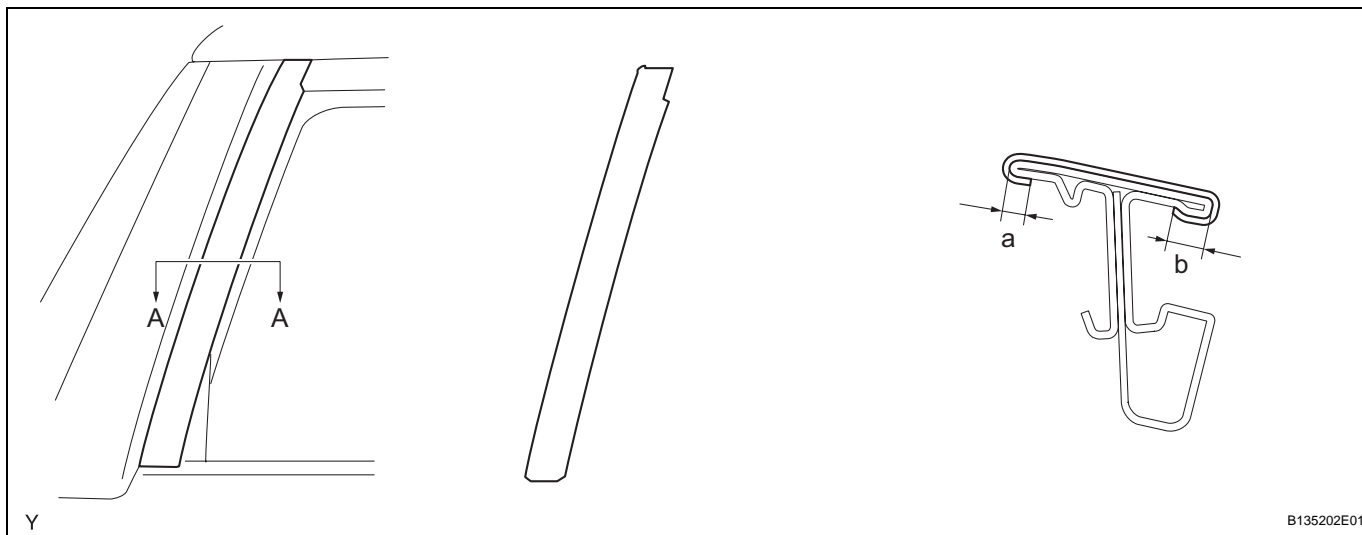

Installation position

Mark	Measurement
a	2 to 4 mm (0.079 to 0.157 in.)
b	4 to 6 mm (0.157 to 0.236 in.)

4. **INSTALL FRONT DOOR WINDOW LOWER FRAME**
HINT:
Use the same procedure as for the RH side (See page [ED-21](#)).
5. **INSTALL FRONT DOOR LOWER FRAME BRACKET GARNISH**
HINT:
Use the same procedure as for the RH side (See page [ED-21](#)).
6. **INSTALL FRONT DOOR LOWER FRAME SUB-ASSEMBLY**
HINT:
Use the same procedure as for the RH side (See page [ED-21](#)).
7. **INSTALL FRONT DOOR GLASS RUN**
HINT:
Use the same procedure as for the RH side (See page [ED-21](#)).
8. **INSTALL FRONT DOOR WEATHERSTRIP**
HINT:
Use the same procedure as for the RH side (See page [ED-22](#)).
9. **INSTALL FRONT DOOR GLASS OUTER WEATHERSTRIP ASSEMBLY** (See page [ET-40](#))
10. **INSTALL OUTER REAR VIEW MIRROR ASSEMBLY** (See page [ET-41](#))

11. INSTALL FRONT DOOR NO. 2 SERVICE HOLE COVER

HINT:

Use the same procedure as for the RH side (See page [ED-24](#)).**12. INSTALL FRONT DOOR TRIM BOARD SUB-ASSEMBLY**

HINT:

Use the same procedure as for the RH side (See page [ED-24](#)).**13. INSTALL FRONT DOOR ARMREST BASE UPPER PANEL**

HINT:

Use the same procedure as for the RH side (See page [ED-25](#)).**14. CONNECT CABLE TO NEGATIVE BATTERY TERMINAL**

Torque: 3.9 N*m (40 kgf*cm, 35 in.*lbf)