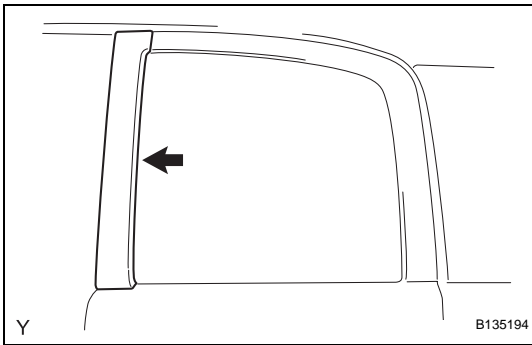

## REMOVAL

### HINT:

The procedure described below is for the LH side. Use the same procedure for both the RH and LH sides, unless otherwise specified.

1. **REMOVE ACCESS PANEL REAR WEATHERSTRIP**  
HINT:  
Use the same procedure as for the RH side (See page [ED-29](#)).
2. **REMOVE LAP BELT OUTER ANCHOR COVER**  
HINT:  
Use the same procedure as for the RH side (See page [ED-29](#)).
3. **REMOVE ACCESS DOOR INSIDE HANDLE SUB-ASSEMBLY**  
HINT:  
Use the same procedure as for the RH side (See page [ED-29](#)).
4. **REMOVE CUP HOLDER**  
HINT:  
Use the same procedure as for the RH side (See page [ED-29](#)).
5. **REMOVE ACCESS DOOR TRIM BOARD SUB-ASSEMBLY**  
HINT:  
Use the same procedure as for the RH side (See page [ED-30](#)).
6. **REMOVE CENTER PILLAR UPPER GARNISH**  
HINT:  
Use the same procedure as for the RH side (See page [ED-30](#)).
7. **REMOVE ACCESS DOOR OPENING TRIM**  
HINT:  
Use the same procedure as for the RH side (See page [ED-32](#)).
8. **REMOVE ACCESS PANEL WEATHERSTRIP**  
HINT:  
Use the same procedure as for the RH side (See page [ED-32](#)).
9. **REMOVE ACCESS DOOR GLASS OUTER WEATHERSTRIP (See page [ET-43](#))**
10. **REMOVE ACCESS DOOR GLASS SUB-ASSEMBLY (See page [WS-58](#))**

**11. REMOVE NO. 4 BLACK OUT TAPE**

- (a) Using an infrared light, heat the No. 4 black out tape.

**CAUTION:**

**Do not burn yourself with the heated front door panel or infrared light.**

**HINT:**

Heat at 40 to 60°C (104 to 140°F) for 3 to 5 minutes.

- (b) Lift the end portion with your nail and peel it parallel to the attachment surface.

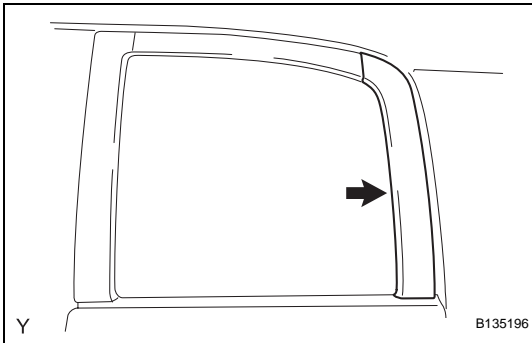
**12. REMOVE NO. 6 BLACK OUT TAPE**

- (a) Using an infrared light, heat the No. 6 black out tape.

**CAUTION:**

**Do not burn yourself with the heated front door panel or infrared light.**

**HINT:**

Heat at 40 to 60°C (104 to 140°F) for 3 to 5 minutes.

- (b) Lift the end portion with your nail and peel it parallel to the attachment surface.

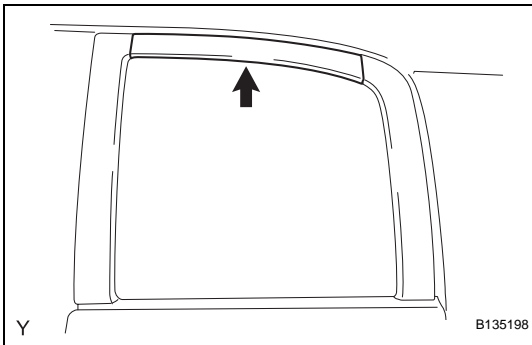
**13. REMOVE NO. 5 BLACK OUT TAPE**

- (a) Using an infrared light, heat the No. 6 black out tape.

**CAUTION:**

**Do not burn yourself with the heated front door panel or infrared light.**

**HINT:**

Heat at 40 to 60°C (104 to 140°F) for 3 to 5 minutes.

- (b) Lift the end portion with your nail and peel it parallel to the attachment surface.